

ready  slate  
by CUP4GROUP

---

INSTALLATION GUIDE



# TABLE OF CONTENTS

READYSLATE® PANELS.....	4
FASTENERS.....	5
PREPARING THE ROOF DECK .....	6
STARTER.....	7
DRIP EDGE.....	8
READYSLATE® INSTALLATION.....	9
LAYOUT LINES.....	10
VALLEY.....	11
VENTILATION.....	15
WALL FLASHINGS.....	16
HIP & RIDGE.....	17
VIDEO INSTALLATION.....	23



### IMPORTANT INFORMATION

Please **consider the following aspects** in order to ensure the correct installation of READYSLATE® panels:

- Before installation check the local building codes for roof requirements.
- READYSLATE® panel temperature should not exceed 50 °C during installation.
- Do not install on pitch less than 12,5 degrees.
- The roof deck or substrate must be prepared before the installation begins (See page 6).
- READYSLATE® backing is a Styrene-Butadiene-Styrene (SBS-modified bitumen) membrane that is suitable for installation with regular roofing underlayment, synthetic felt or HT Ice and Water, metal flashings and polyurethane based sealers. If you intend to use different materials, check with the manufacturer for possible interactions.
- Do not install while the temperature is less than -6 °C.



### RECEIVING AND VERIFYING THE PRODUCT

Upon delivery, **please examine** the product for any possible damage.

Exhaustive quality controls are performed on each and every one of our READYSLATE® panels before they leave our factory. Despite the protective wrapping, damages may occur to the READYSLATE® panels during transport.

Problems should be documented and reported immediately to the freight carrier and to your READYSLATE® supplier.

CUPA PIZARRAS declines all liability for damage caused during transport unless notified within 48 hours of delivery.



### HANDLING AND STORAGE INSTRUCTIONS

Outdoor storage **is not recommended**.

When no other option is available, READYSLATE® panels must be completely covered and protected by a waterproof covering.

Store at a maximum temperature of 43°C. Place the panels on a flat area, preventing them from bending, and with slates facing upwards at all times. Do not remove the packaging until they are ready to be installed.

READYSLATE® panels must be stored in a dry place, protected from rain and extreme temperatures. This product is neither flammable nor toxic.



### AVOID WALKING

READYSLATE® should be installed in a way that eliminates or greatly reduces foot traffic on slopes that already have the product installed, especially on hot days. If it is absolutely necessary to walk on a READYSLATE® roof, then please follow these recommendations:

- Wear soft-soled shoes or foam rubber sole boots to prevent damage.
- Step along the bottom of the panels, avoiding the middle and tops.
- Do not jump or move quickly thus avoiding additional pressure as you step.
- Walk on the balls of your feet directing pressure on the 5 cm area where the slate overlaps.
- A roof walkway pad is recommended to distribute weight across multiple pieces of slate.

# READYSLATE® PANELS



READYSLATE® panels are composed of two layers:

- **Support layer:** Waterproof bituminous self-adhesive membrane.
- **Visible layer:** High quality, hand-quarried slate with a density of 2850 Kg/m<sup>3</sup>. Individual slate pieces are predrilled and marked with an overlap line in order to simplify the installation process

## DESCRIPTION

	READYSLATE 3.5 MM - 18 Kg/m <sup>2</sup>			READYSLATE 5 MM - 20 Kg/m <sup>2</sup>			READYSLATE 7,5 MM - 27 Kg/m <sup>2</sup>		
	BOX	PALLET	LOAD	BOX	PALLET	LOAD	BOX	PALLET	LOAD
UNITS	5 PANELS	36 BOXES	24 PALLETS	4 PANELS	39 BOXES	24 PALLETS	4 PANELS	33 BOXES	24 PALLETS
UNITS/Load	-	-	864 BOXES	-	-	936 BOXES	-	-	792 BOXES*
M <sup>2</sup>	1,5 m <sup>2</sup>	54 m <sup>2</sup>	1296 m <sup>2</sup>	1,2 m <sup>2</sup>	46,8 m <sup>2</sup>	1123,2 m <sup>2</sup>	1,2 m <sup>2</sup>	39,6 m <sup>2</sup>	950,4 m <sup>2</sup>
WEIGHT	27 Kg	1000 Kg	24000 Kg	24 Kg	1000 Kg	24000 Kg	33 Kg	1100 Kg	26500 Kg

\*The number of pallets and boxes per load may vary depending on the destination.

## INSTRUMENTS AND ACCESSORIES

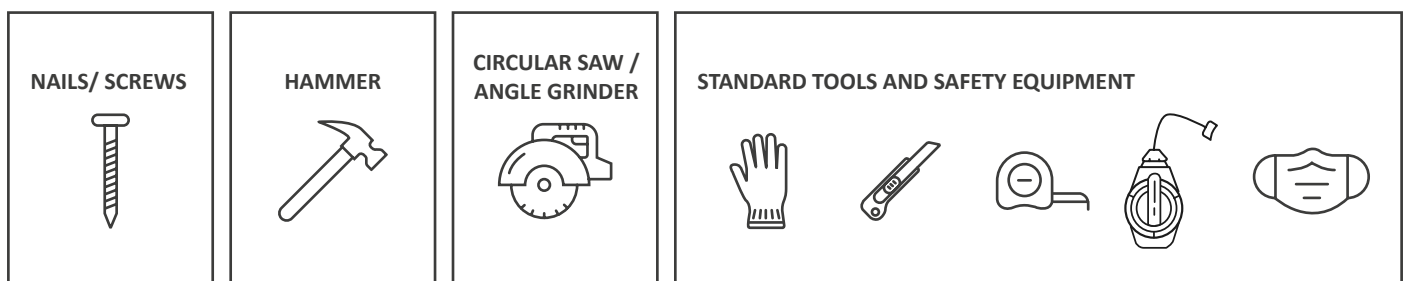

Slate is a natural product and no two pieces are alike. Therefore it is impossible to create the same slate twice, even from the same quarry. Each piece may show variations in color and texture. These small differences are what makes slate roofs naturally beautiful and impossible to imitate.

# FASTENERS

## STANDARD FASTENERS: STAINLESS STEEL NAILS

READYSLATE® panels must be installed with  $\varnothing \geq 7$  mm flat head nails,  $\geq 2,7$  mm and minimum 38 mm long. Copper or stainless steel, smooth shank nails are recommended. Ring shank nails may be used in high wind or coastal areas.

Aluminium and galvanised nails are not recommended, especially in coastal applications and other saline or corrosive environments. Longer nails may be needed depending on the thickness of the substrate. Nails should penetrate into the substrate a minimum of 25 mm. Consult the local building code for specific requirements.

**For valleys, ridges, and other cuts it may be necessary to drill an additional hole to ensure every piece of slate is secured by 2 fasteners. Before nailing additional nails, it is necessary to pre-drill with a 4 mm drill bit.**

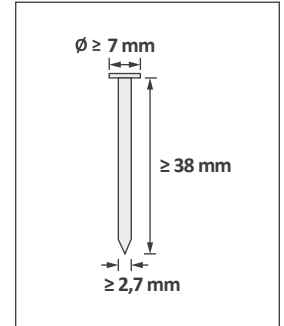

## NAILING PROCEDURE

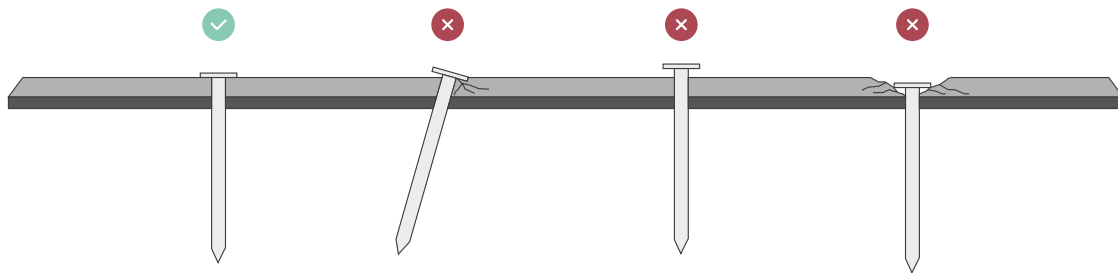

### NAIL COVERAGE: 40 NAILS/M<sup>2</sup>

\*Install 12 nails per panel using the pre-punched holes

## EXTERIOR BLACK ROOFING SCREW - USED FOR FINAL PIECE OF HIP & RIDGE OR OTHER EXPOSED AREAS AS REQUIRED

4,9 x 45 mm. Exterior steel screw with neoprene washer (commonly used for metal roofing applications).

Pre-drill a hole with a 5 mm drill bit before fastening the screw.

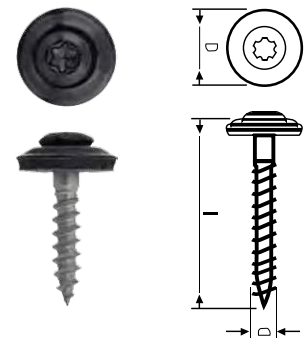

## STANDARD FASTENERS: SCREWS

Screws are an alternative option to nails. Stainless steel self tapping screws 3,5 x 38 mm are recommended.

Make sure the screws are properly driven. Overdriven screws may crack the slates and inadequate underdriven or misaligned screws may prevent the next row from being laid correctly. Repeatedly screwing and unscrewing the same panel can compromise the waterproof performance of the system.

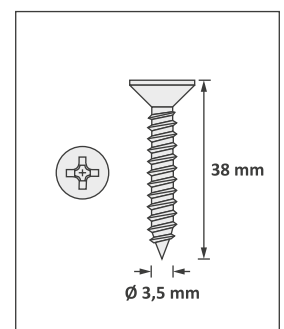

# PREPARING THE ROOF DECK

---

**a.** The roof substructure must consist of one of the following options:

- 25mm x 152mm sized timber boards.
- 16 mm or greater APA plywood or OSB.

*\* For other substructures please contact our Technical Department: [readyslate@cupapizarras.com](mailto:readyslate@cupapizarras.com)*

**b.** The substrate must be clean and kept dry during installation. Repair any holes, wet or uneven areas.

**c.** A roofing underlay is necessary. A water resistant breathable underlayment, roofing felt, synthetic felt or HT Peel and Stick SBS are accepted options. Please consult your local building codes department for approved underlayments and applications.

**d.** High Temp Ice and Water self adhesive roofing underlay is required in low pitch areas, chimneys or other roof penetrations. It is also recommended for all valleys, rakes, eaves, ridges and hips.



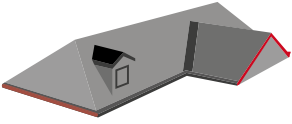

# STARTER

Option 1: Starter with 6mm bend

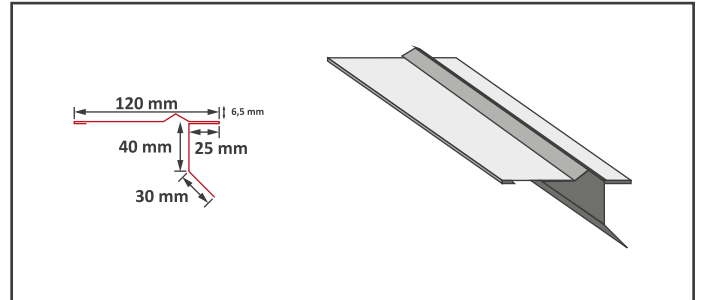
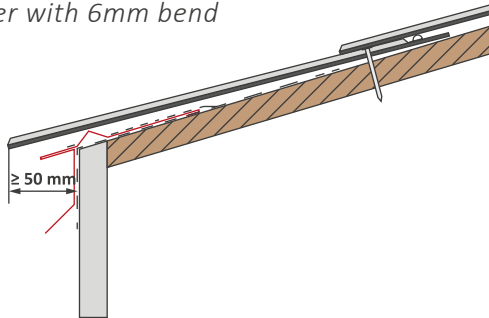

Option 2: Starter with stripwood

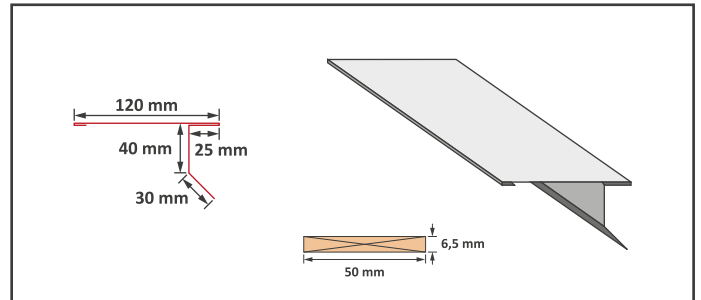
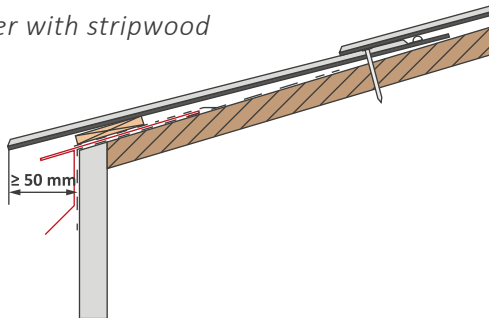

Option 3: Starter with gutter

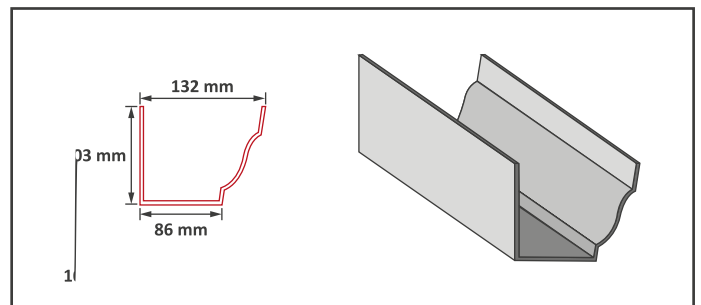
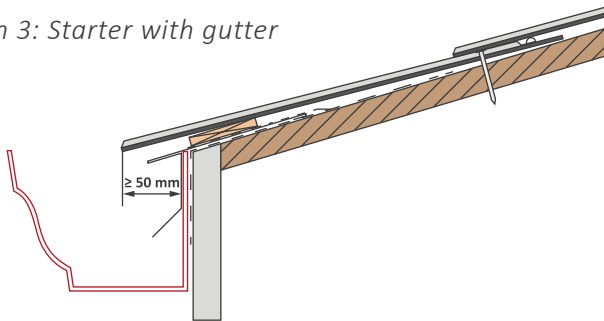

Option 4: vented eaves protector

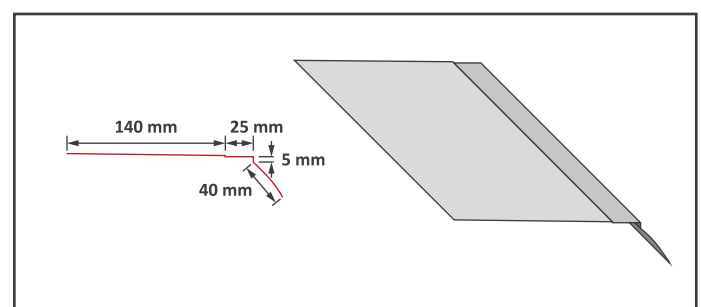
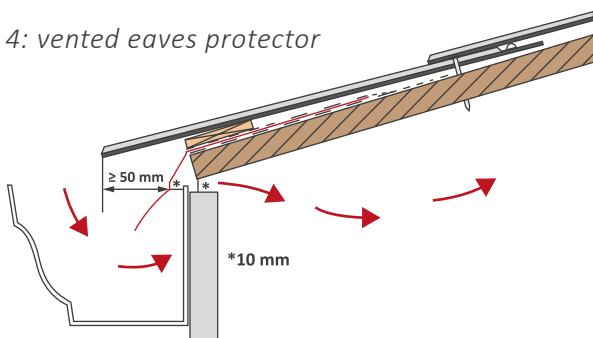

Option 5: Fascia vent

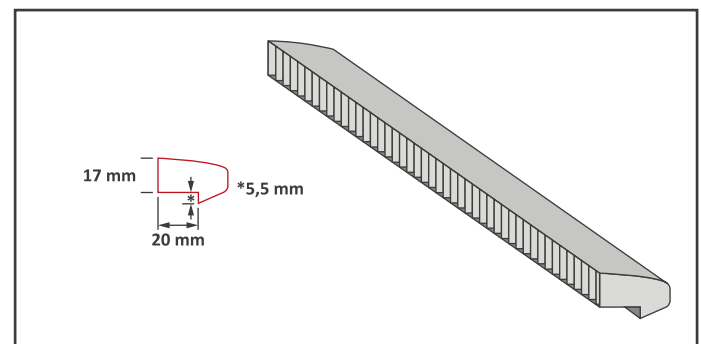
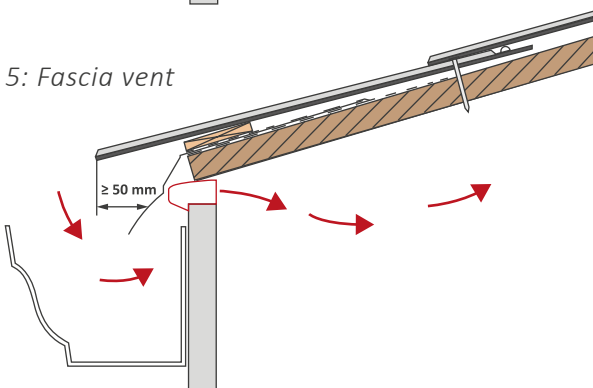

# DRIP EDGE

**Option 1:** 50mm side edge flashing black alu/metal

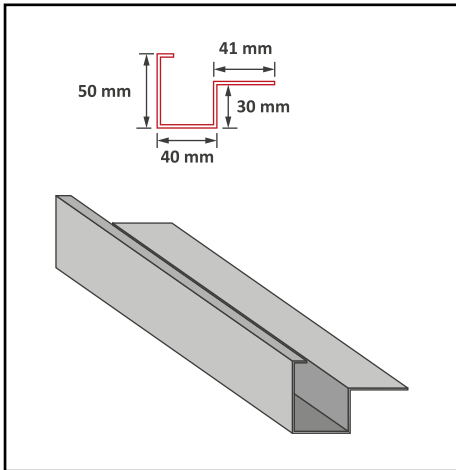

First row

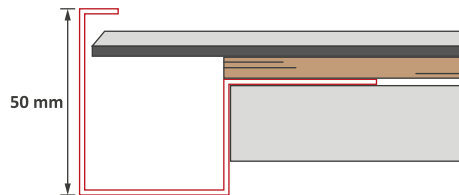

Following rows

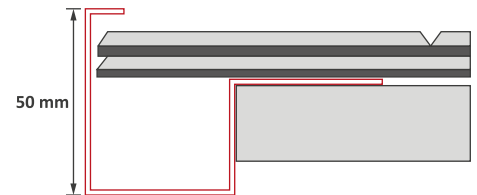

**Option 2:** 18mm slate dry verge- black alu/metal

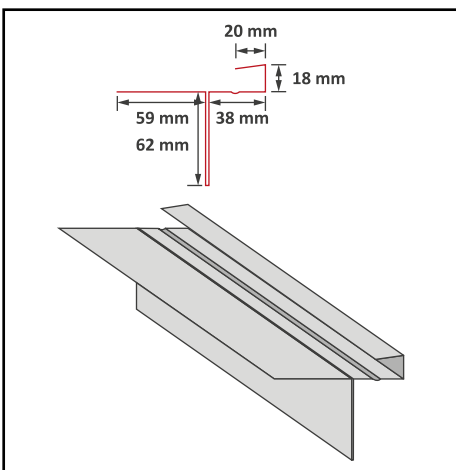

First row

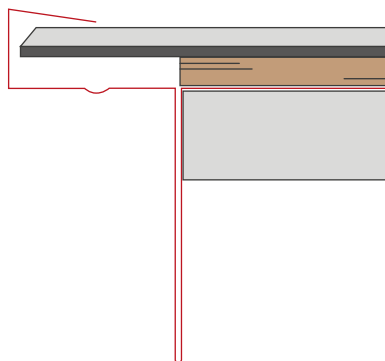

Following rows

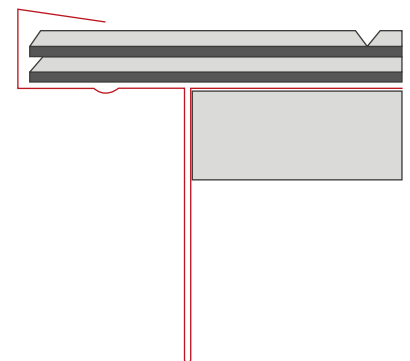

**Option 3:** 20mm raised drip edge flashing black alu/metal

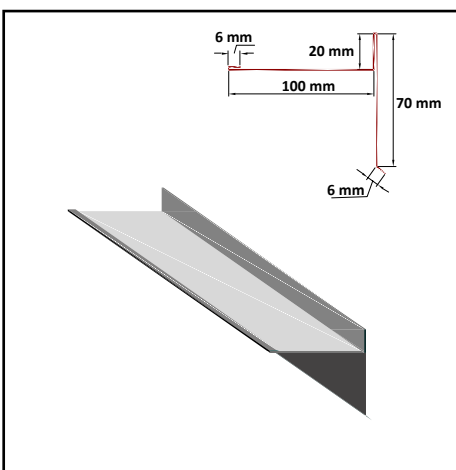

First row

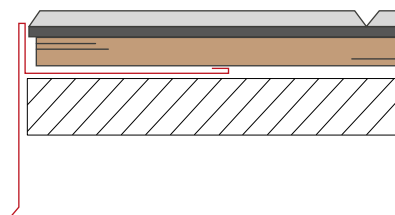

Following rows

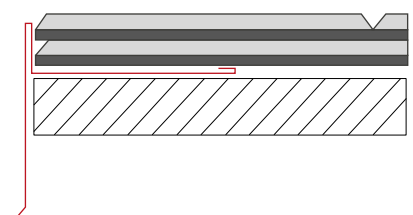

# READYSLATE® INSTALLATION

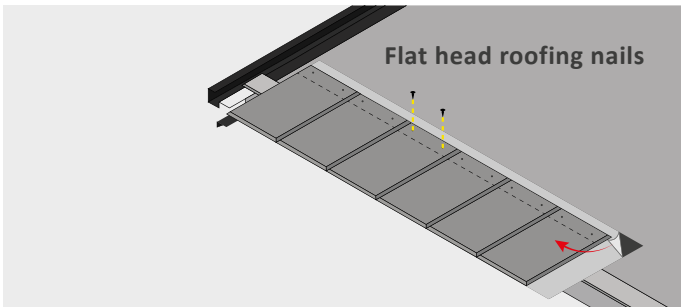

Lay the first READYSLATE® panel down and nail each piece of slate using the pre-punched holes provided. Ensure the panel extends 5-7 cm over the edge of the eaves. Once the panel install is complete, peel back the protective film on the top and right side of the panel.

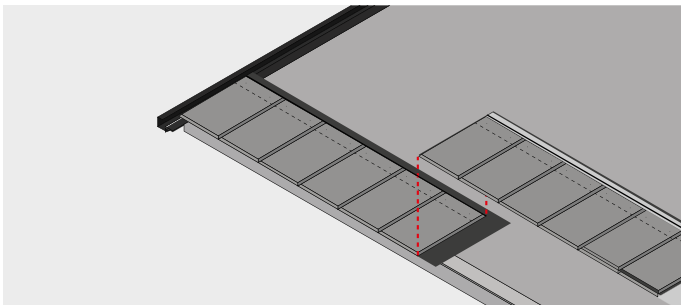

Repeat for all READYSLATE® panels in the first row, covering the waterproof sheet area at the right of each panel. Remember to make all necessary measurements and markings to ensure the overhang distance is maintained. For the final slate on a row, measure the gap between the last slate of the panel and the edge of the roof and cut to size. It is recommended to save the remaining part of the panel for hip and ridge or to start the next row.

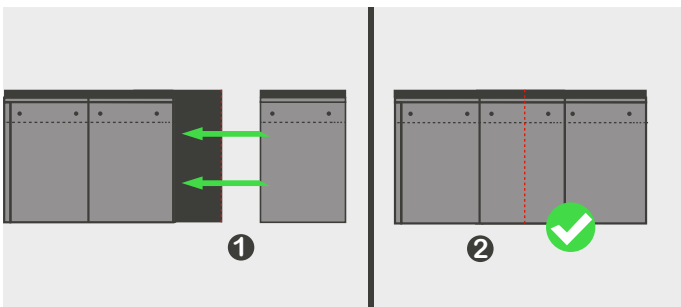

**⚠ WARNING!** The first piece of slate from each panel must butt against the last piece of slate on the previous panel. An excessive gap in between panels can cause both pre-mature failure and a noticeable gap in the pattern from the ground. Contrarily, the first piece should not be installed over or on top of the last piece of slate on the previous panel. A proper installation between panels should be flush and mimic the distance between the pieces of slate on a full Readyslate panel.

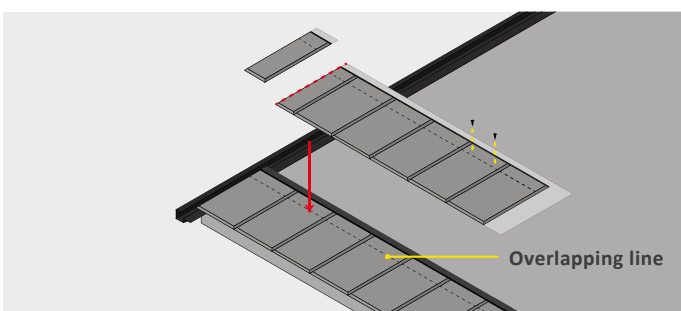

Use a angle grinder or a circular saw with an appropriate masonry blade to cut half of the first slate tile. Remaining rows must always be installed overlapping the joints of the preceding panel. All READYSLATE® modules are marked with an overlapping line. The lower edge of all panels must line up with this line to ensure all panels are correctly positioned.

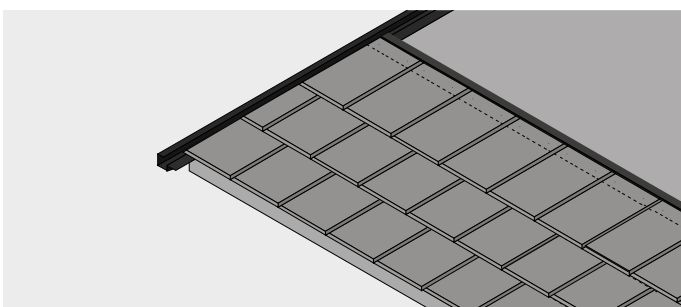

Start the third course by cutting the first piece of slate from a full panel. Use the five full pieces on the remaining panel to start the third row. Use four and a half pieces on the panel to start the fourth row before returning to a full panel on the fifth row. Follow the instructions above for all remaining rows. We recommend saving cut panels for other areas of the roof and hip and ridge applications.

# LAYOUT LINES

The use of chalk lines is a great method to guarantee a straight installation.

## HORIZONTAL LINES

To ensure the READYSLATE® panels are positioned correctly, mark horizontal chalk lines from the bottom starting in 20cm from the eaves. READYSLATE® panels must overhang a minimum of 5cm where the gutters are to be installed. If the desired overhang is greater than above, the first line's distance will be calculated by subtracting 25cm minus the desired overhang length. Then continue to mark the remaining lines every 25cm to be in accordance with the overlapping line. **Horizontal lines are marked every 25cm to indicate where the panels overlap.**

## VERTICAL LINES

Vertical lines help to keep panels aligned. Marking out chalk lines every 4-6 slates should be sufficient.

## REESTABLISHING THE STARTER COURSE

**Marking out vertical lines becomes critical when your roof installation includes elements** such as dormers or gables that interrupt the first course of installation. Install the READYSLATE® panels to a point past the obstruction, then place one panel on the top and use it as a reference to mark the new lines to the bottom. Calculate the alternance of slates and halves (every 2 rows- 50cm- there is a full slate in the same position) making sure the first slate from the bottom left side must be a full or a half.

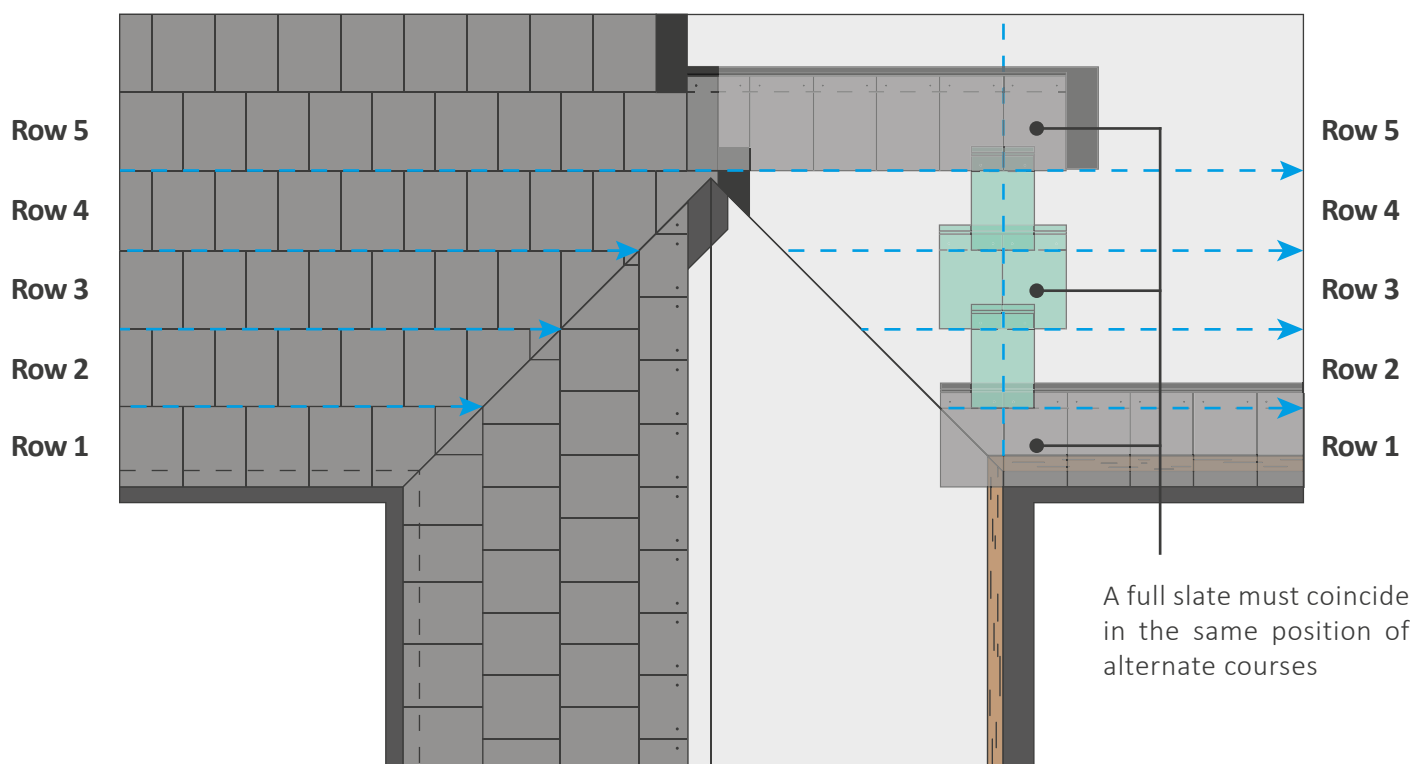

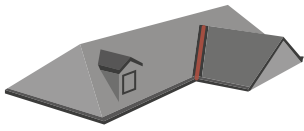

# VALLEY

## Option 1. Closed valley

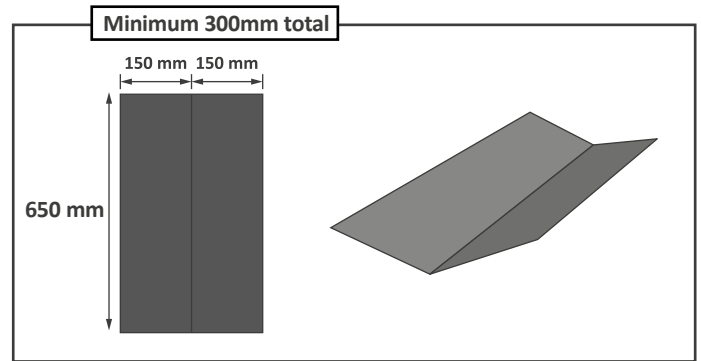

Valley before installing READYSLATE®

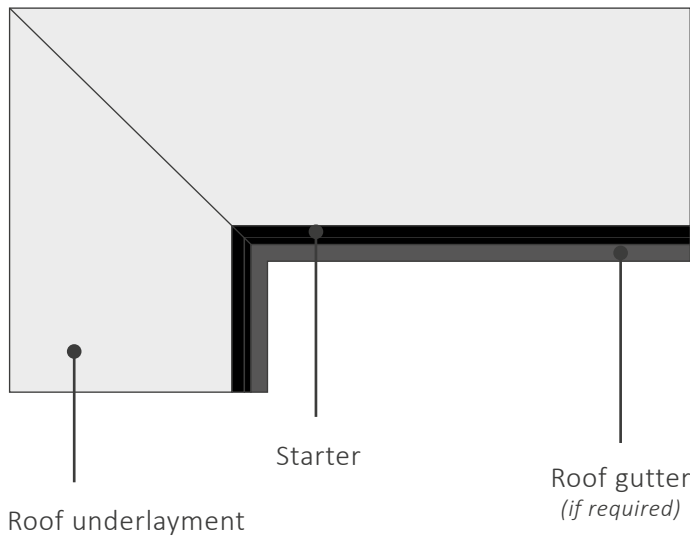

Valley after installing READYSLATE®

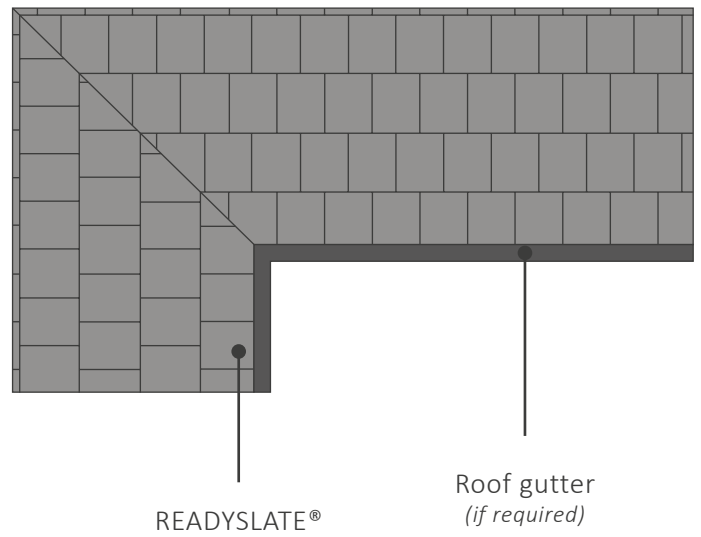

## Closed valley details

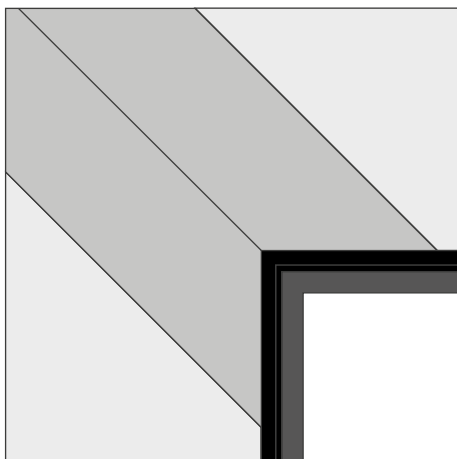

Substructure covered with starter and underlayment. Installing an ice and water barrier is required.

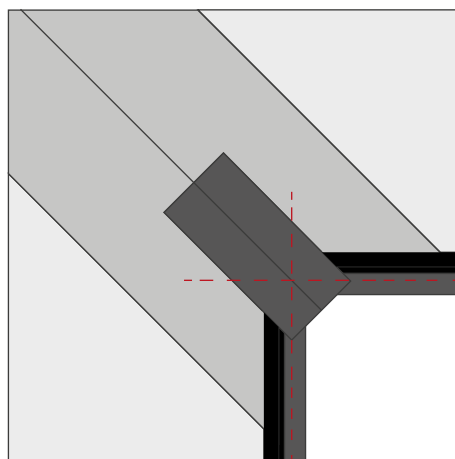

To install the first piece of valley flashing, cut the flashing to match the angle of the valley, allowing for a 5 cm overhang.

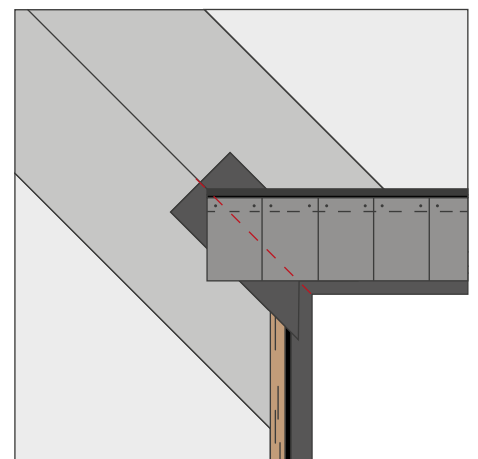

Place the first READYSLATE® panel and mark it to match the angle.

# VALLEY

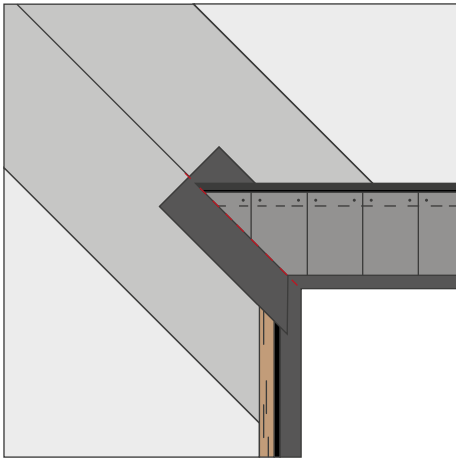

Cut the READYSLATE® panel to size.\*

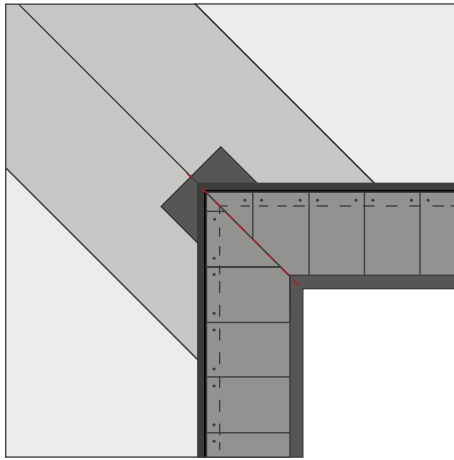

Place the adjacent READYSLATE® panel, mark the angle and cut to size.\*

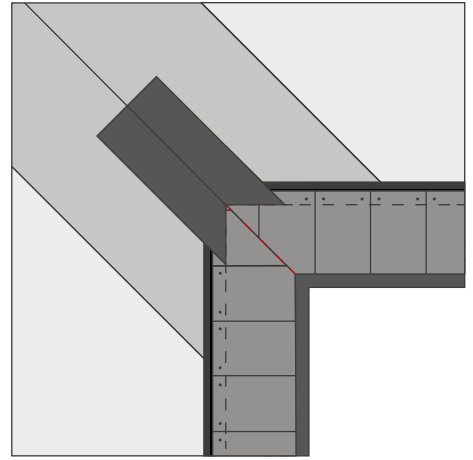

Cut the angle of the 2<sup>nd</sup> flashing as per the 2 overlap lines and nail it.

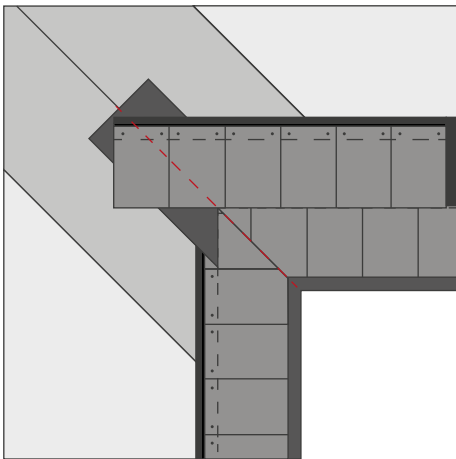

Place the 2<sup>nd</sup> row of READYSLATE® panel.

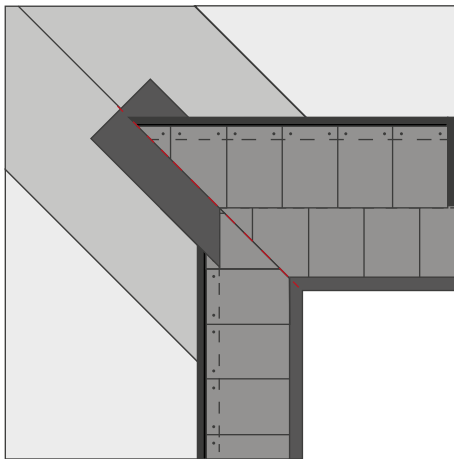

Cut it to size as previously indicated.\*

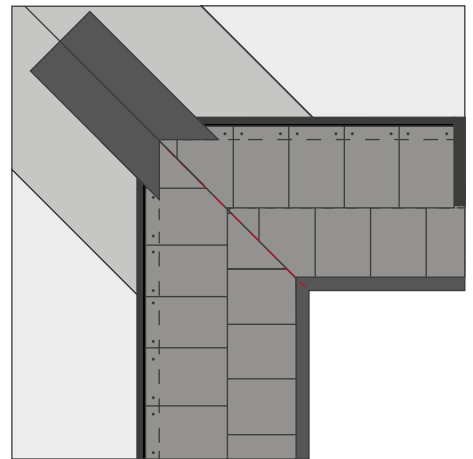

Continue the installation interweaving flashings and READYSLATE® panels.

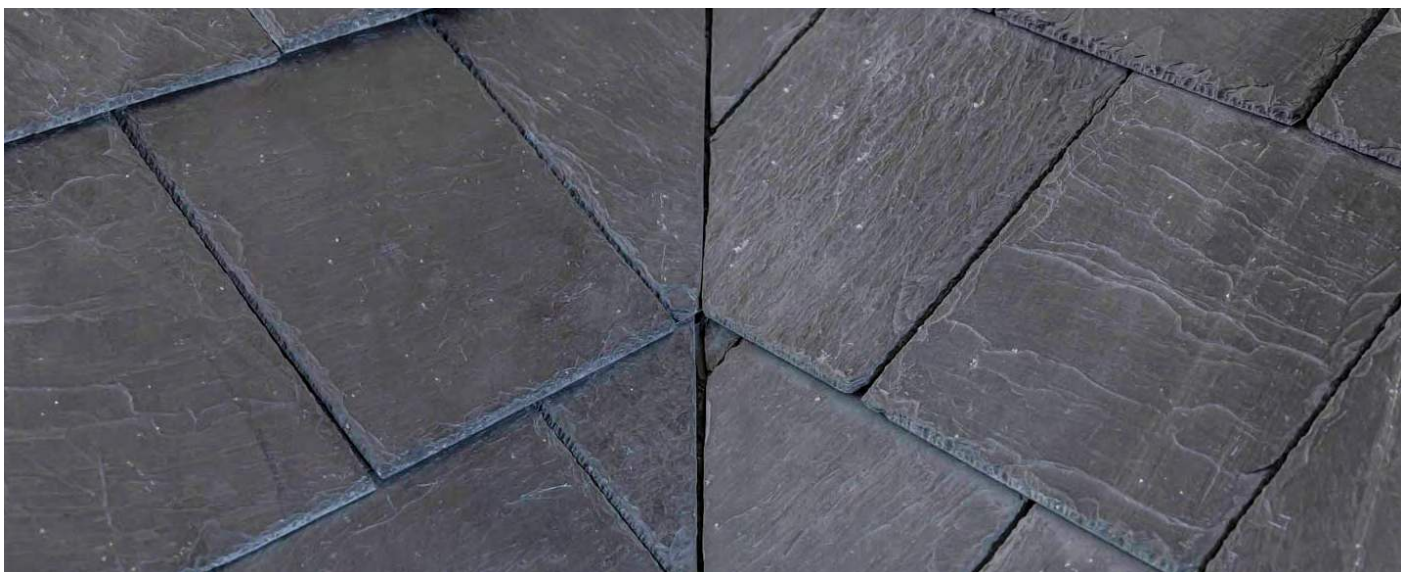

\* It may be necessary to drill an additional hole to make sure every piece of slate is secured by 2 fasteners.

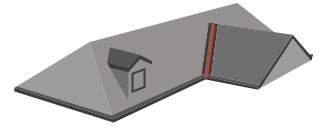

**a. Open valley**

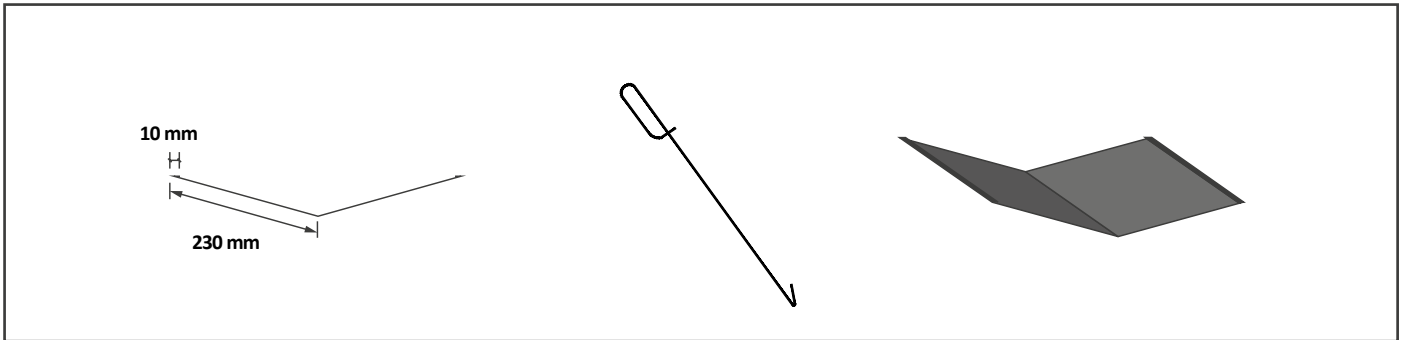

Valley before installing READYSLATE®

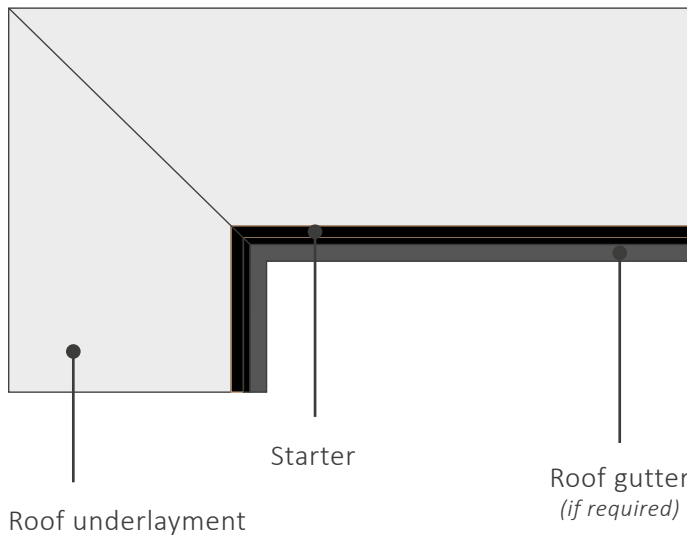

Valley after installing READYSLATE®

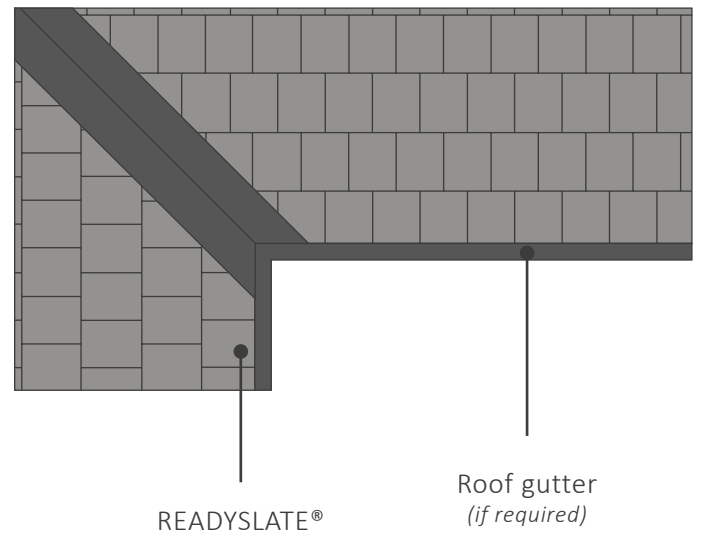

**Open valley details**

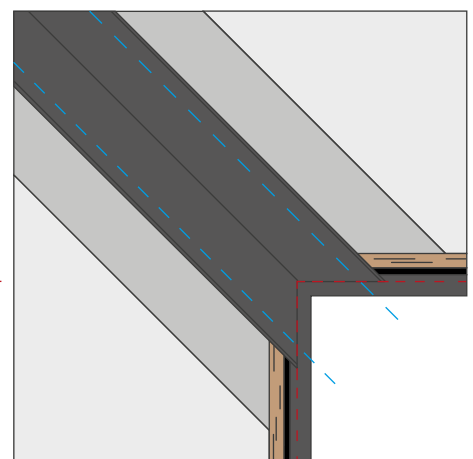
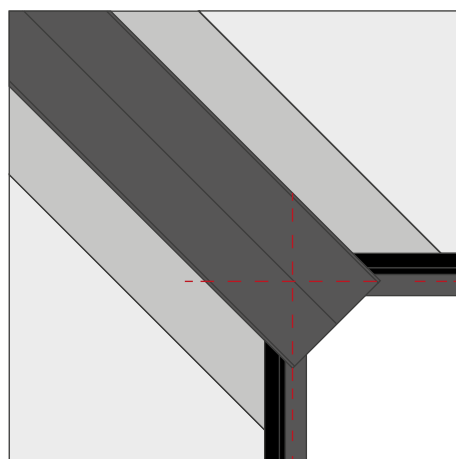
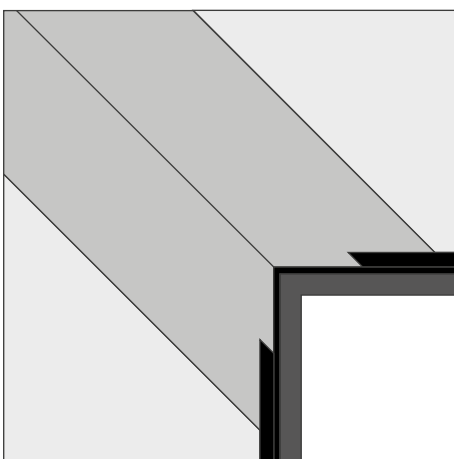

Substructure covered with underlayment and starter cut to size. Installing an ice and water barrier is required.

To install the first piece of valley flashing, measure the flashing to match the angle of the valley, allowing for a 5 cm overhang.

Cut the flashing and placing, allowing for a 5 cm overhang on the eaves.

# VALLEY

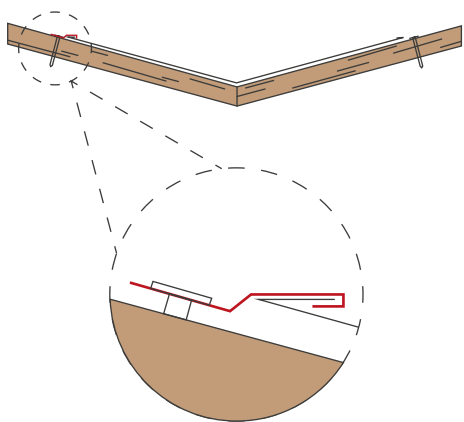

The metal flashing is attached to the substructure using clips.

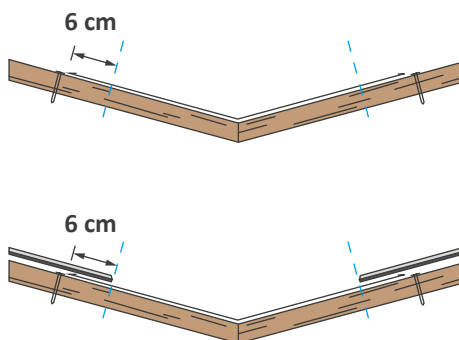

READYSLATE® needs to overlap the metal a minimum of 6 cm. Use a chalk line to create a reference line on the metal to follow.

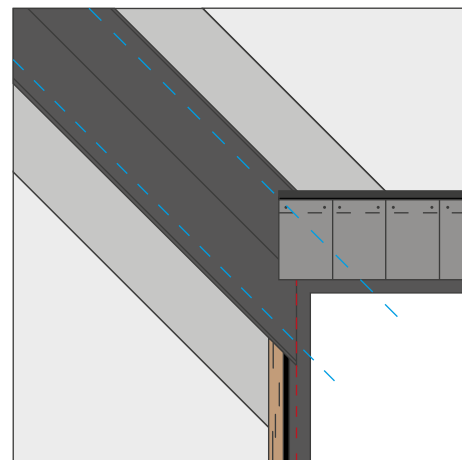

Place the first READYSLATE® panel and mark it to match the angle. It may be necessary to drill an additional hole to make sure every piece of slate is secured by 2 fasteners.

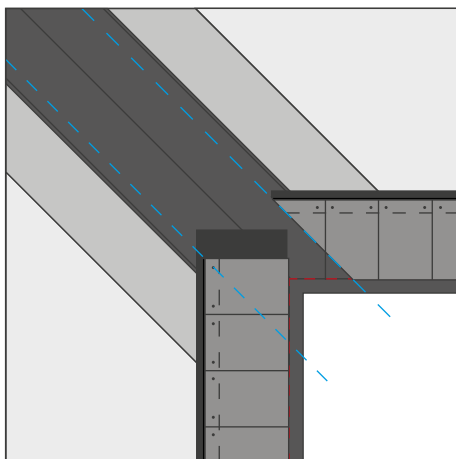

Cut the READYSLATE® panel to size. Place the adjacent panel on the other side of the valley, mark it and cut it.

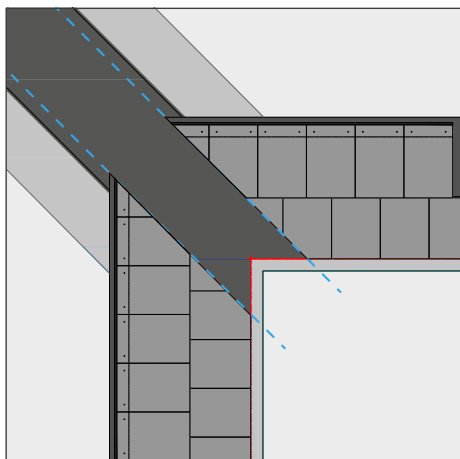

Continue with the installation of the remaining READYSLATE® panels as previously indicated.

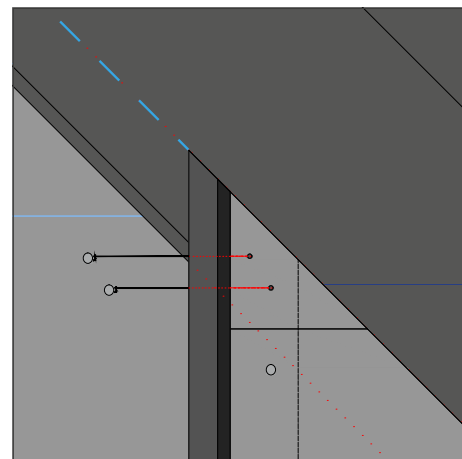

In some cases, a small piece of slate may need to be secured with hooks to keep from nailing through the valley metal.



# VENTILATION

Air circulation under the roof is vital to prevent moisture issues and prevent excess heat in your attic. Proper ventilation will extend the life of the roof, improve the comfort of the home and reduce energy costs.

## INTAKE: SOFFIT VENTS

On most residential buildings, soffit vents are installed under the eaves to allow cool air into the attic.

## EXHAUST VENTS

Exhaust vents allow hot and moist air to flow out of the attic. The number of exhaust vents should be calculated using the manufacturer's instructions. ReadySlate is compatible with most standard residential roof ventilation options including:

### 1. Static roof vents

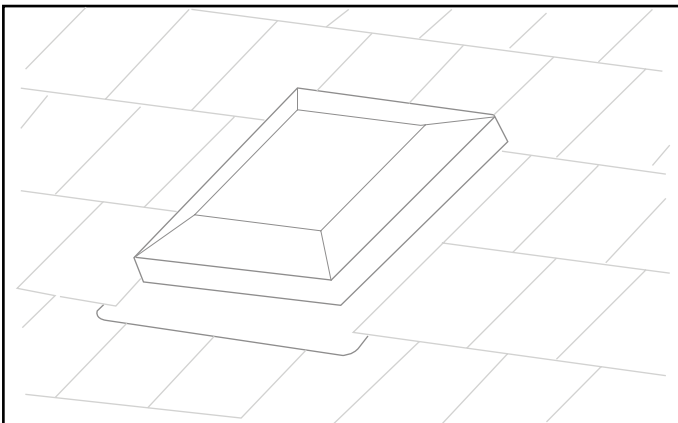

### 2. Power roof vents

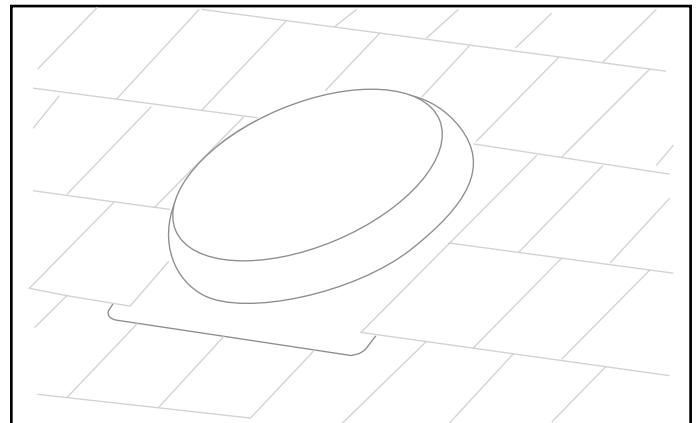

### 3. Ridge vents

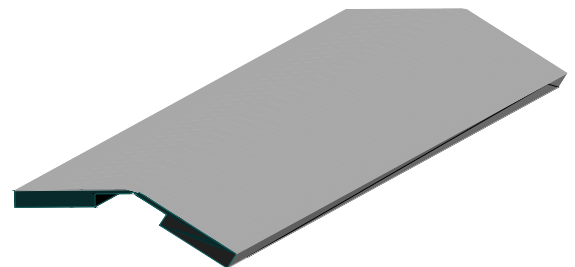
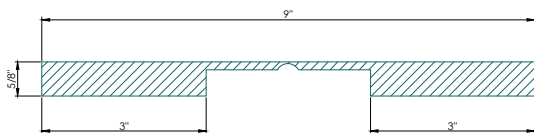

Ridge vent

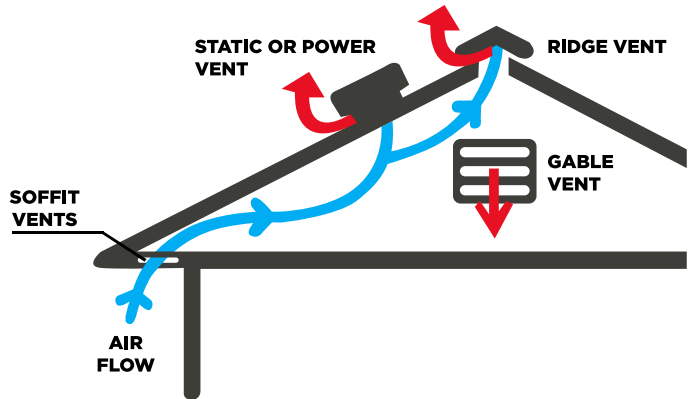
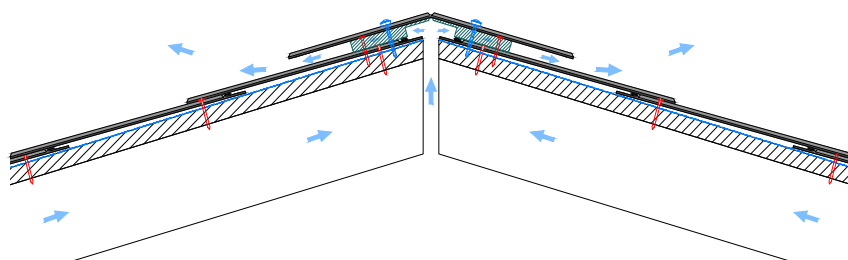

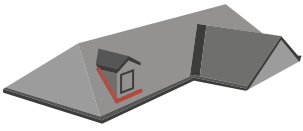

# WALL FLASHINGS

## a. Side: step flashings + sidings

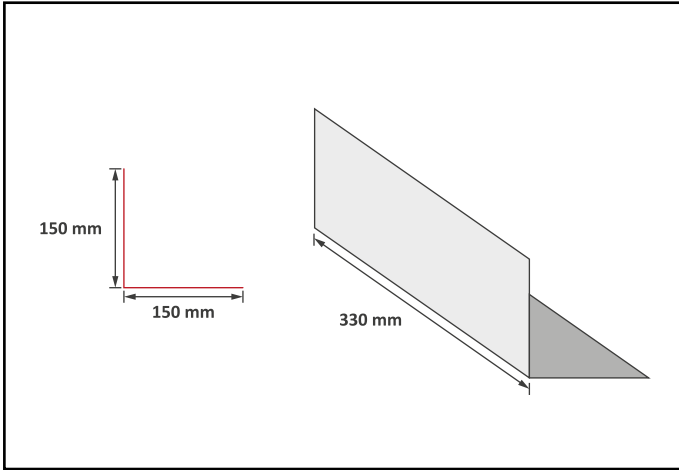

Install the step flashings (nailing to the substructure) before every row of READYSLATE® and cover them with a strip of high temp ice and water before installing the siding.

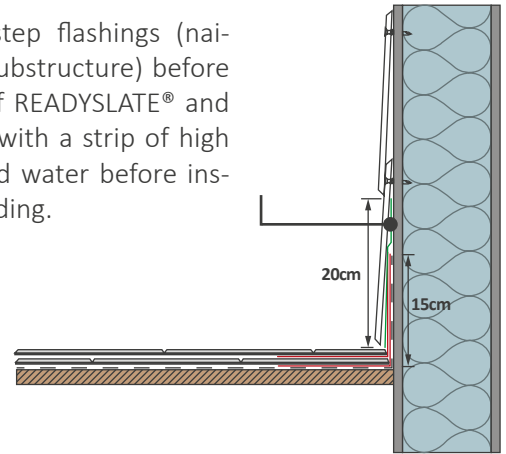

## b. Side: step flashings + counterflashing

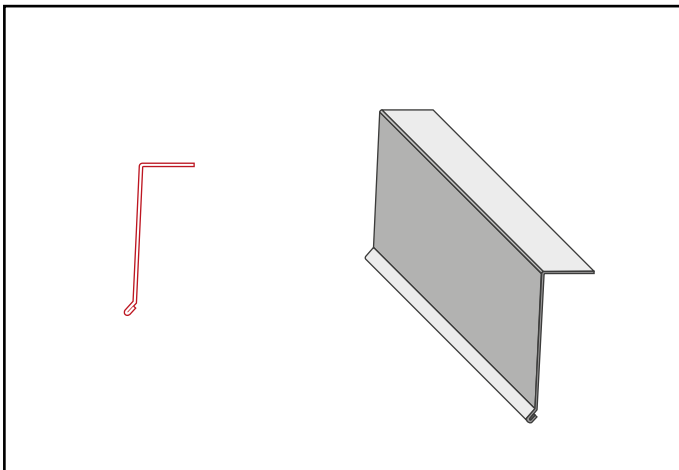

Install the step flashing (nailing to the substructure) before every row and cover with high temp ice and water. Install the counterflashing and seal with a continuous bead of sealant.

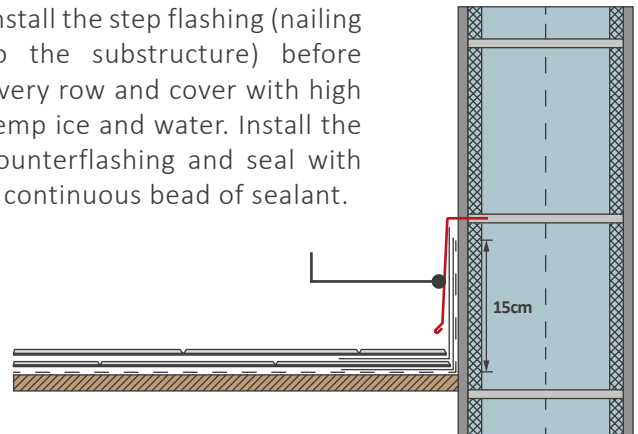

## c. Front

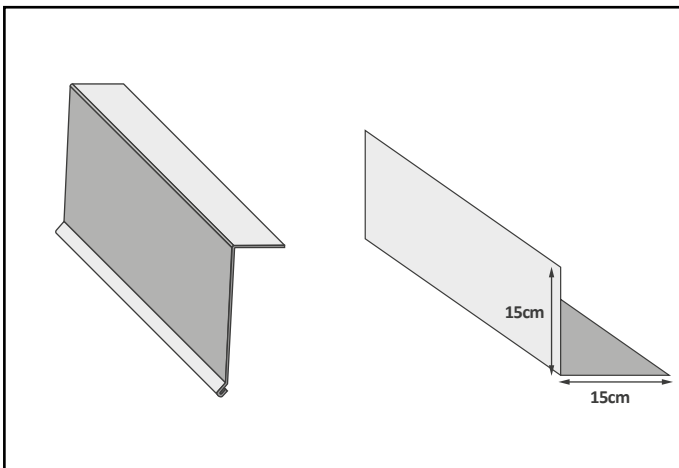

Install the flashing (nailing to the wall) after the last row of READYSLATE® panels and cover with the counterflashing. Then seal with a continuous bead of sealant.

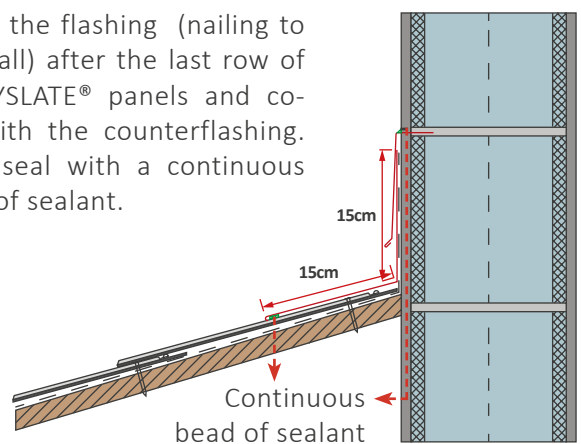

# HIP AND RIDGE

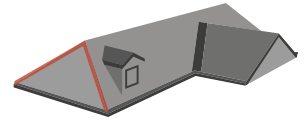

a. HIP: Readyslate + metal flashing  
+ hip and ridge caps

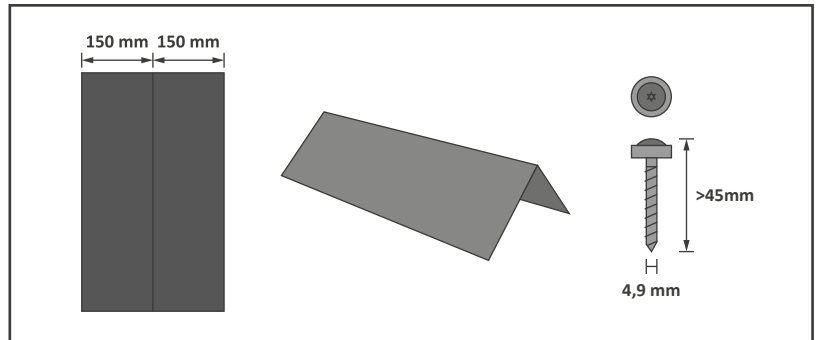

Hip before installing READYSLATE®

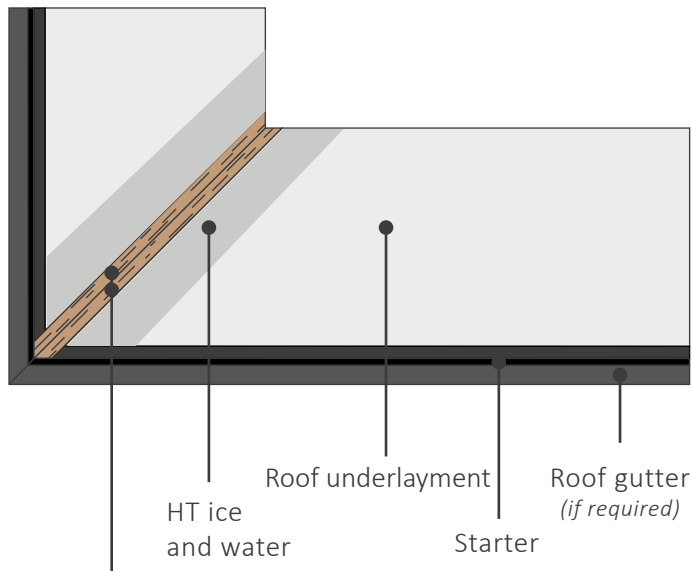

Wood strips at both sides of the hip

Hip after installing READYSLATE®

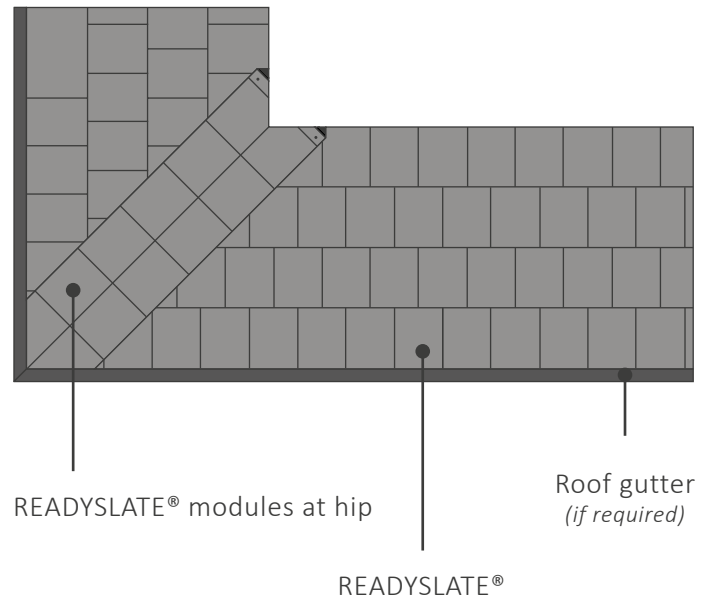

## Hip details

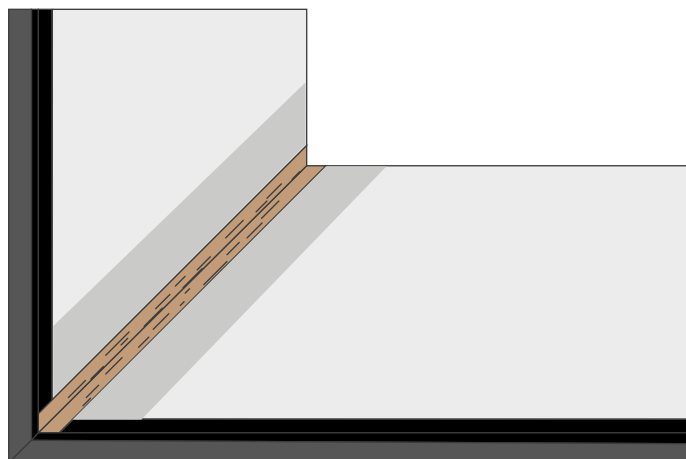

Substructure with gutter, starter and underlayment. Install high temp ice and water and then the wood strips on both sides of the hip.

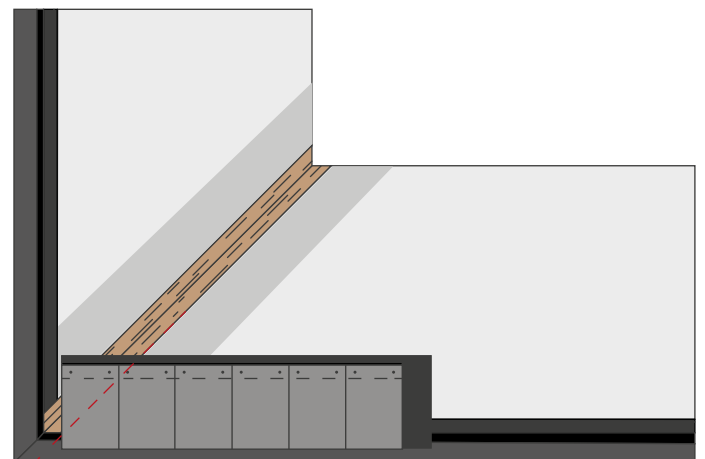

Place the first READYSLATE® panel and mark it to match the angle.

# HIP AND RIDGE

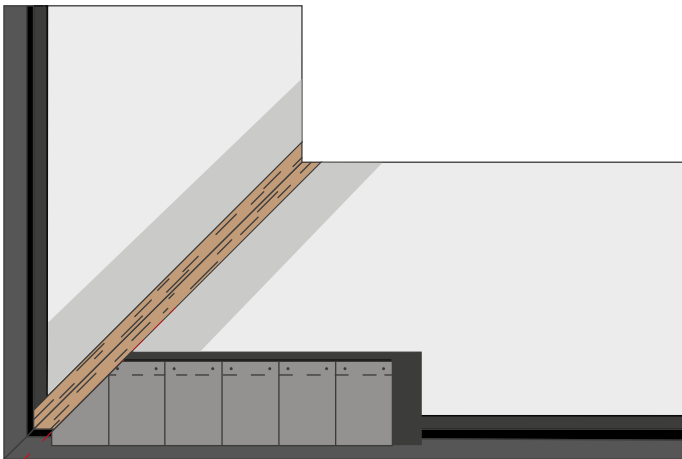

Cut the first READYSLATE® panel to size.

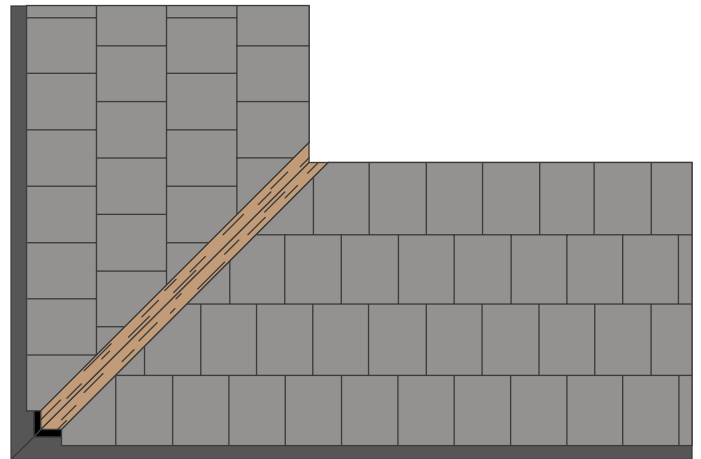

Cover the roof with READYSLATE® panels, installing as previously indicated.

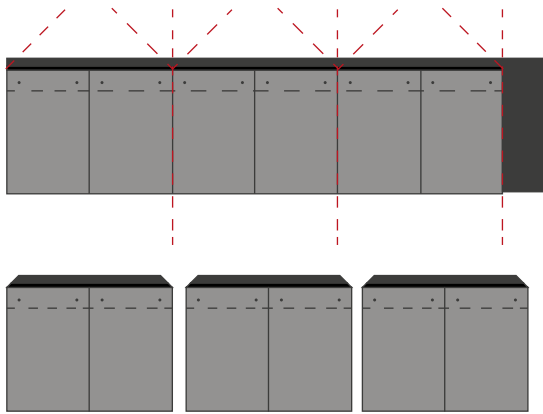

Cut the panel to get 3 hip and ridge caps of 2 pieces of slate each and cut off the corners of the membrane.

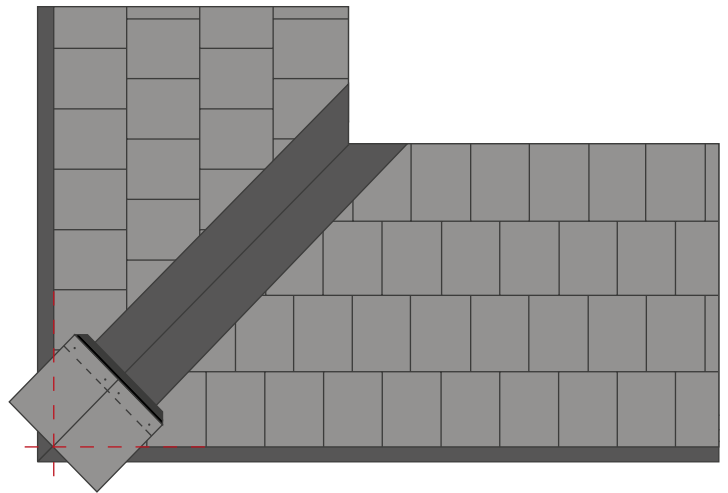

Install the hip flashing before covering it with READYSLATE®. Make sure the flashing extends to or below the overlapping line. Place, cut and nail the READYSLATE® caps on the hip.

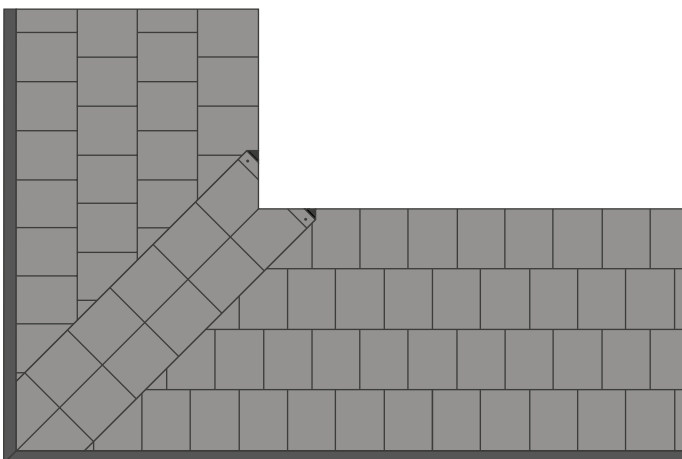

The outside hole can be nailed after pre-drilling with a 5 mm drill bit to avoid cracking the slate underneath. For lower pitched roofs, drill a new hole in between the top and the bottom. Every piece of slate must be secured by 2 fasteners, drilling an additional hole may be necessary.

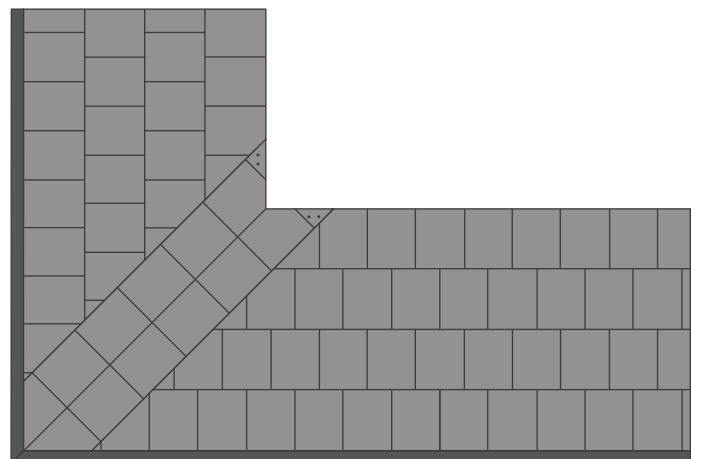

Use specified screws with rubber washers to secure the last piece, even if it's a small section. Apply a continuous bead of sealant to the joint between the two pieces of the READYSLATE® cap to prevent UV exposure.

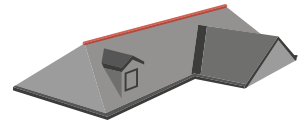

**b. RIDGE:** Readyslate + metal flashing + hip and ridge caps

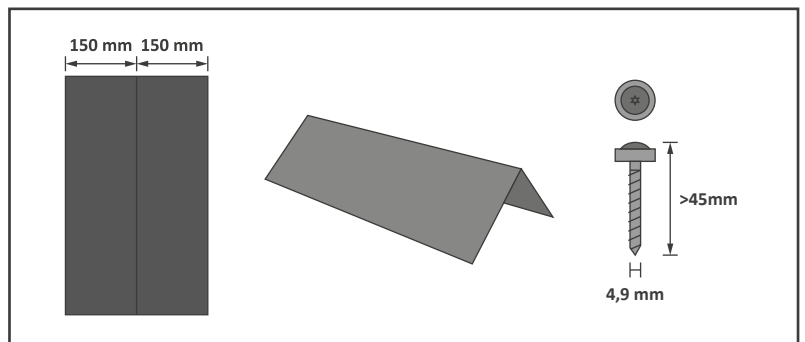

Ridge before installing READYSLATE®

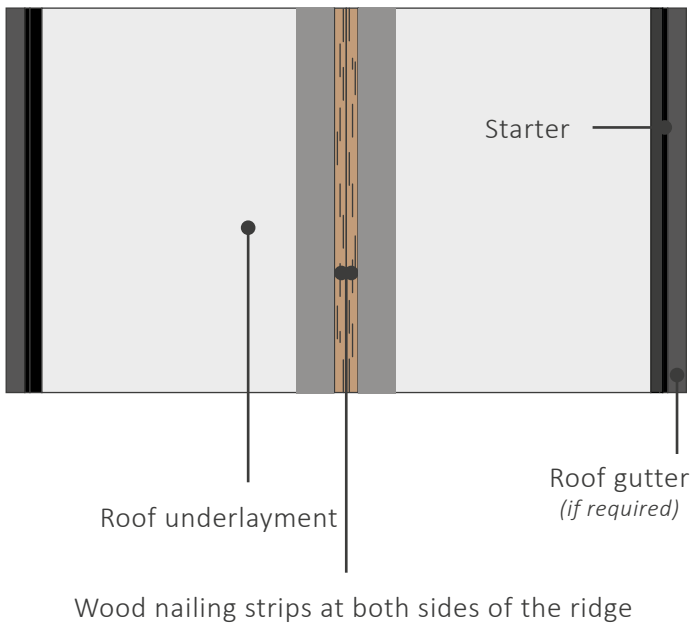

Ridge after installing READYSLATE®

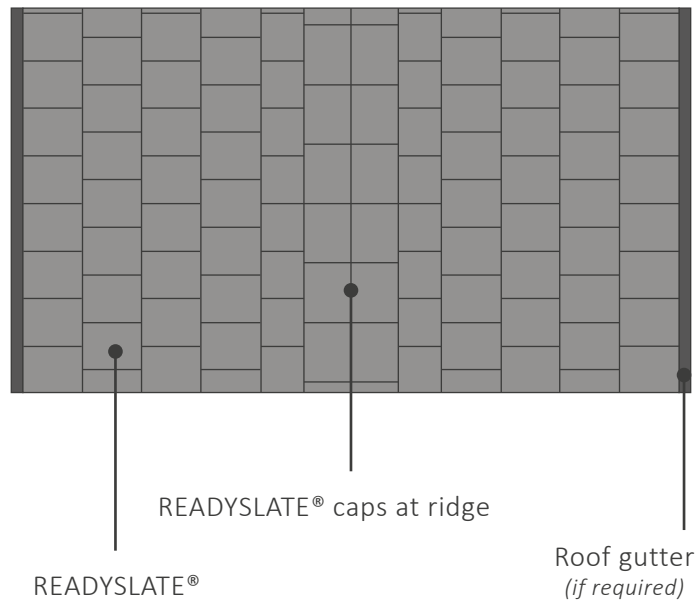

**Ridge details**

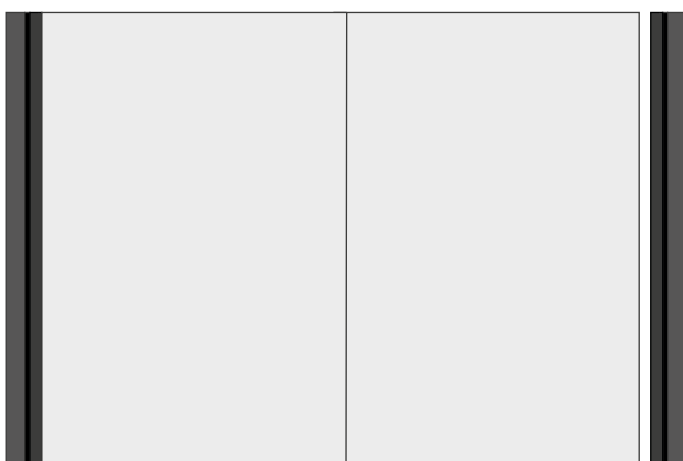

Substructure with gutter, starter and underlayment.

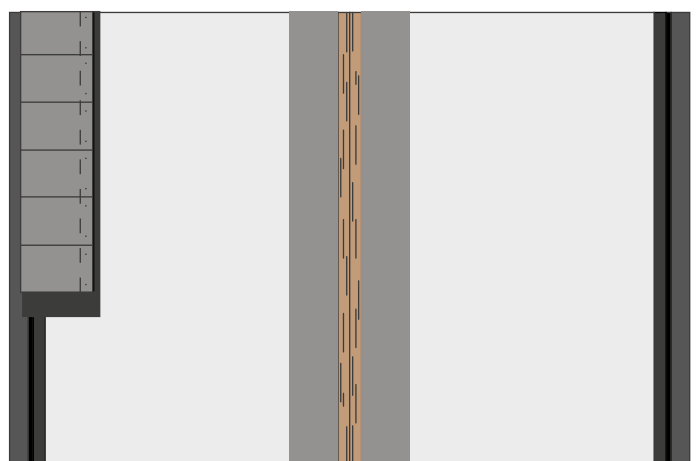

Next, install high temp ice and water and then the wood nailing strips.

# HIP AND RIDGE

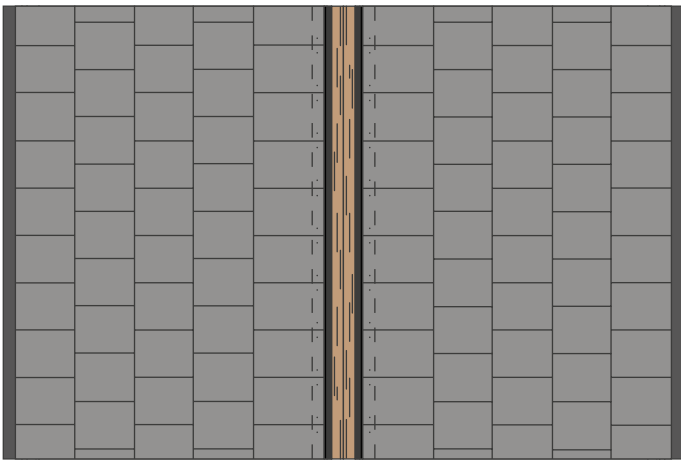

Install the roof with READYSLATE® panels up to the ridge.

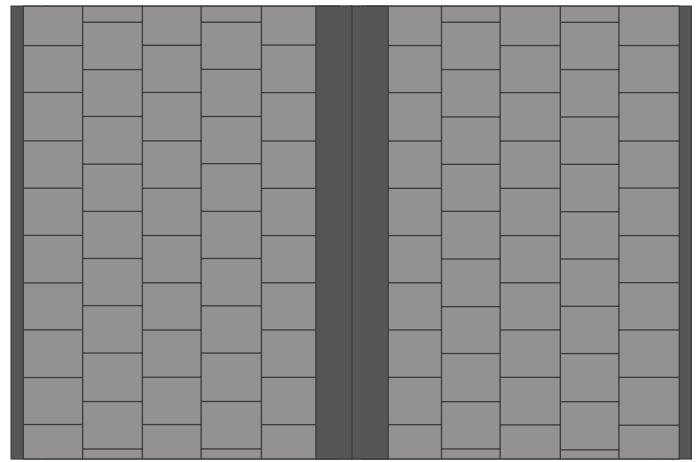

Install the metal ridge flashing (min. 6" at each side of the ridge).

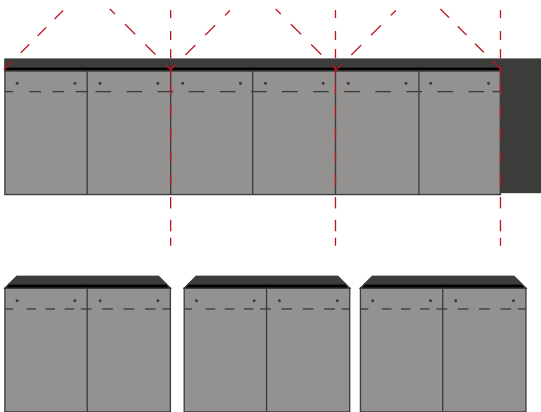

Cut the panel to get 3 hip and ridge caps of 2 pieces of slate each and cut off the corners of the membrane.

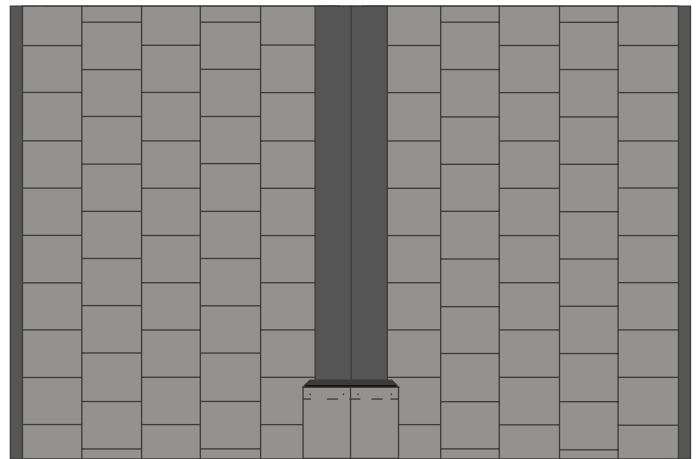

Place and nail the READYSLATE® caps on the ridge.

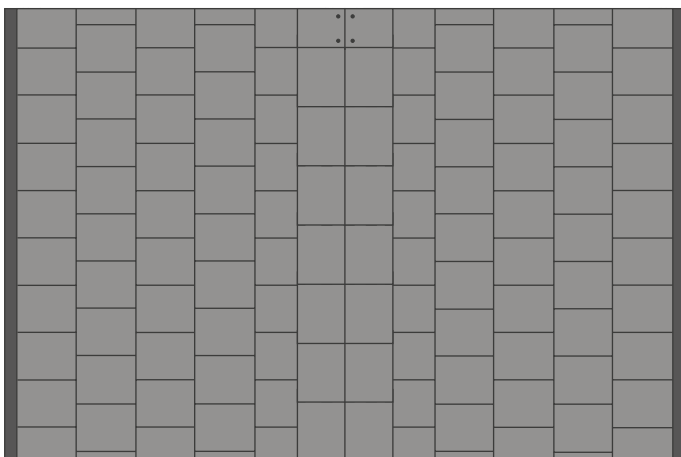

The outside hole can be nailed after pre-drilling with a 5 mm drill bit to avoid cracking the slate underneath. For lower pitched roofs, drill a new hole in between the top and the bottom. Every piece of slate must be secured by 2 fasteners, drilling an additional hole may be necessary.

Use specified screws with rubber washers to secure the last piece, even if it's a small section. Apply a continuous bead of sealant to the joint between the two pieces of the READYSLATE® cap to prevent UV exposure.

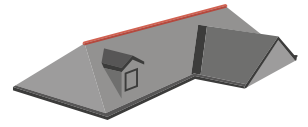

### c. Monopitch ridge

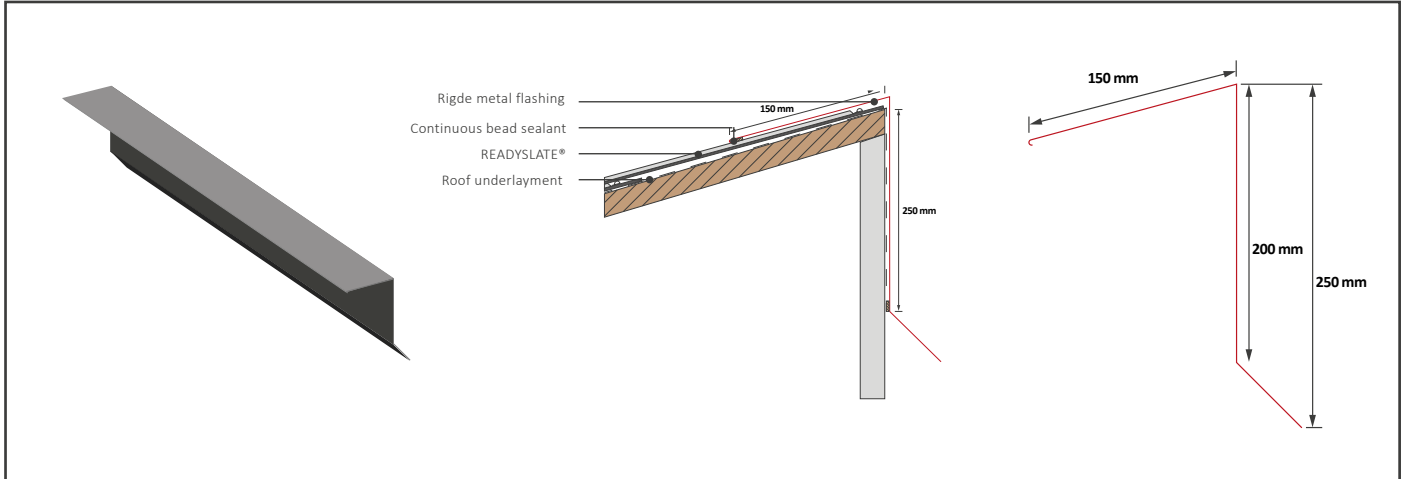



# ready»slate

**N**atural slate is a durable and non-fading material that requires little maintenance. Properly maintained, the roof is more resistant, effective and beautiful. However, regular inspection and roof cleaning will extend your roof's lifespan.

There are some minimum requirements which you should carry out regularly:

- General inspection of the waterproofing elements, overview all the additional works : flashings, fasteners, accessories, gutters... all meeting points.
- Check and clean the water drainage systems, periodical removal of moss, mold and other sediments and residues...

One of the best things you can do for your roof doesn't involve much work at all: pay attention to it! Keep an eye on your roof.

**READYSLATE® ROOFING SYSTEM IS  
MANUFACTURED BY CUPA PIZARRAS**

# VIDEO INSTALLATION

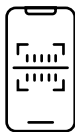

*We have produced a series of videos solving the most frequently asked questions when installing READYSLATE. You only have to scan the QR code with your phone to access the videos.*

1 / PREPARATION



2 / STARTER



3 / DRIP EDGE



4 / FIRST COURSE



5 / READYSLATE® INSTALLATION



6 / SKYLIGHT FLASHING



7 / STEP FLASHING



8 / LAYOUT LINES



9 / OPEN VALLEY



10 / CLOSED VALLEY



11 / HIP & RIDGE



12 / CHIMNEY FLASHING



13 / RIDGE VENT



ready>>slate

UK: +44 (0) 20 3318 4455  
INT: +34 988 335 410  
readyslate@cupapizarras.com



READYSLATE.COM

